



IEEE 802.3af PD Interface Controller For Power-Over-Ethernet

General Description

The MAX5940A/MAX5940B/MAX5940C/MAX5940D provide complete interface function for a powered device (PD) to comply with the IEEE 802.3af standard in a power-over-ethernet system. MAX5940A/MAX5940B/MAX5940C/MAX5940D provide the PD with a detection signature, a classification signature, and an integrated isolation switch with programmable inrush current control. These devices also feature power-mode undervoltage lockout (UVLO) with wide hysteresis and power-good outputs. The MAX5940A/MAX5940B are available with an absolute maximum rating of 80V and the MAX5940C/MAX5940D are rated for an absolute maximum rating of 90V.

An integrated MOSFET provides PD isolation during detection and classification. All devices guarantee a leakage current offset of less than 10 μ A during the detection phase. A programmable current limit prevents high inrush current during power-on. The device features power-mode UVLO with wide hysteresis and long deglitch time to compensate for twisted-pair cable resistive drop and to assure glitch-free transition between detection, classification, and power-on/-off phases.

The MAX5940A/MAX5940C provide an active-high (PGOOD) open-drain output and a fixed UVLO threshold. The MAX5940B/MAX5940D provide both active-high (PGOOD) and active-low ($\overline{\text{PGOOD}}$) outputs and have an adjustable UVLO threshold with the default value compliant to the 802.3af standard. All devices are designed to work with or without an external diode bridge.

The MAX5940A/MAX5940B/MAX5940C/MAX5940D are available in 8-pin SO packages and are rated over the extended temperature range of -40°C to +85°C.

Applications

IP Phones Security Cameras
Wireless Access Nodes IEEE 802.3af Power Devices
Computer Telephony

Features

- ◆ Fully Integrated IEEE 802.3af-Compliant PD Interface
- ◆ PD Detection and Programmable Classification Signatures
- ◆ Less than 10 μ A Leakage Current Offset During Detection
- ◆ Integrated MOSFET For Isolation and Inrush Current Limiting
- ◆ 90V Absolute Maximum Rating (MAX5940C/MAX5940D)
- ◆ Gate Output Allows External Control of the Internal Isolation MOSFET
- ◆ Programmable Inrush Current Control
- ◆ Programmable Undervoltage Lockout (MAX5940B/MAX5940D Only)
- ◆ Wide UVLO Hysteresis Accommodates Twisted-Pair Cable Voltage Drop
- ◆ PGOOD/ $\overline{\text{PGOOD}}$ Outputs to Enable Downstream DC-DC Converters
- ◆ -40°C to +85°C Operating Temperature Range

Ordering Information

PART	TEMP RANGE	PIN-PACKAGE	UVLO
MAX5940AESA	-40°C to +85°C	8 SO	Fixed
MAX5940BESA	-40°C to +85°C	8 SO	Adjustable
MAX5940CESA	-40°C to +85°C	8 SO	Fixed
MAX5940DESA	-40°C to +85°C	8 SO	Adjustable

Pin Configurations appear at end of data sheet.

Typical Operating Circuits

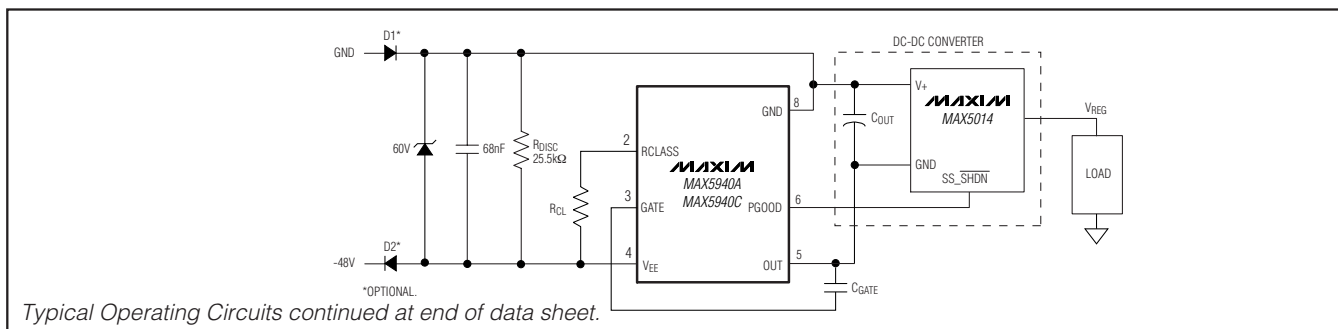

IEEE 802.3af PD Interface Controller For Power-Over-Ethernet

ABSOLUTE MAXIMUM RATINGS

(All voltages are referenced to V_{EE} , unless otherwise noted.)
 GND (MAX5940A/MAX5940B)-0.3V to +80V
 GND (MAX5940C/MAX5940D).....-0.3V to +90V
 OUT, $\overline{\text{PGOOD}}$ -0.3V to (GND + 0.3V)
 RCLASS, GATE-0.3V to +12V
 UVLO-0.3V to +8V
 $\overline{\text{PGOOD}}$ to OUT.....-0.3V to (GND + 0.3V)
 Maximum Input/Output Current (continuous)
 OUT to V_{EE} 500mA

GND, RCLASS to V_{EE} 70mA
 UVLO, $\overline{\text{PGOOD}}$, $\overline{\text{PGOOD}}$ to V_{EE} 20mA
 GATE to V_{EE}80mA
 Continuous Power Dissipation ($T_A = +70^\circ\text{C}$)
 8-Pin SO (derate 5.9mW/ $^\circ\text{C}$ above $+70^\circ\text{C}$).....470mW
 Operating Temperature Range-40 $^\circ\text{C}$ to +85 $^\circ\text{C}$
 Storage Temperature Range-65 $^\circ\text{C}$ to +150 $^\circ\text{C}$
 Junction Temperature+150 $^\circ\text{C}$
 Lead Temperature (soldering, 10s)+300 $^\circ\text{C}$

Stresses beyond those listed under "Absolute Maximum Ratings" may cause permanent damage to the device. These are stress ratings only, and functional operation of the device at these or any other conditions beyond those indicated in the operational sections of the specifications is not implied. Exposure to absolute maximum rating conditions for extended periods may affect device reliability.

ELECTRICAL CHARACTERISTICS

($V_{IN} = (\text{GND} - V_{EE}) = 48\text{V}$, GATE = $\overline{\text{PGOOD}}$ = $\overline{\text{PGOOD}}$ = OUT = OPEN, UVLO = V_{EE} , $T_A = -40^\circ\text{C}$ to $+85^\circ\text{C}$, unless otherwise noted. Typical values are at $T_A = +25^\circ\text{C}$. All voltages are referenced to V_{EE} , unless otherwise noted.) (Note 1)

PARAMETER	SYMBOL	CONDITIONS	MIN	TYP	MAX	UNITS	
DETECTION MODE							
Input Offset Current (Note 2)	I_{OFFSET}	$V_{IN} = 1.4\text{V}$ to 10.1V			10	μA	
Effective Differential Input Resistance (Note 3)	dR	$V_{IN} = 1.4\text{V}$ up to 10.1V with 1V step, OUT = $\overline{\text{PGOOD}}$ = GND	550			k Ω	
CLASSIFICATION MODE							
Classification Current Turn-Off Threshold (Note 4)	$V_{\text{TH,CLSS}}$	V_{IN} rising	20.8	21.8	22.5	V	
Classification Current (Notes 5, 6)	I_{CLASS}	$V_{IN} = 12.6\text{V}$ to 20V, $R_{\text{DISC}} = 25.5\text{k}\Omega$	Class 0, $R_{\text{CL}} = 10\text{k}\Omega$	0	2	mA	
			Class 1, $R_{\text{CL}} = 732\Omega$	9.17	11.83		
			Class 2, $R_{\text{CL}} = 392\Omega$	17.29	19.71		
			Class 3, $R_{\text{CL}} = 255\Omega$	26.45	29.55		
			Class 4, $R_{\text{CL}} = 178\Omega$	36.6	41.4		
POWER MODE							
Operating Supply Voltage	V_{IN}	$V_{IN} = (\text{GND} - V_{EE})$			67	V	
Operating Supply Current	I_{IN}	Measure at GND, not including R_{DISC}		0.4	1	mA	
Default Power Turn-On Voltage	$V_{\text{UVLO, ON}}$	V_{IN} increasing	MAX5940A/MAX5940C	34.3	35.4	36.6	V
			MAX5940B/MAX5940D, UVLO = V_{EE}	37.4	38.6	39.9	
Default Power Turn-Off Voltage	$V_{\text{UVLO, OFF}}$	V_{IN} decreasing, UVLO = V_{EE} for MAX5940B/MAX5940D	30			V	
Default Power Turn-On/Off Hysteresis	$V_{\text{HYST, UVLO}}$	MAX5940A/MAX5940C	4.2			V	
		MAX5940B/MAX5940D, UVLO = V_{EE}	7.4				
External UVLO Programming Range	$V_{\text{IN, EX}}$	Set UVLO externally (MAX5940B/MAX5940D only) (Note 7)	12		67	V	
UVLO External Reference Voltage	$V_{\text{REF, UVLO}}$		2.400	2.460	2.522	V	
UVLO External Reference Voltage Hysteresis	HYST	Ratio to $V_{\text{REF, UVLO}}$	19.2	20	20.9	%	
UVLO Bias Current	I_{UVLO}	UVLO = 2.460V	-1.5		+1.5	μA	

IEEE 802.3af PD Interface Controller For Power-Over-Ethernet

MAX5940A/MAX5940B/MAX5940C/MAX5940D

ELECTRICAL CHARACTERISTICS (continued)

($V_{IN} = (GND - V_{EE}) = 48V$, $GATE = \overline{PGOOD} = PGOOD = OUT = OPEN$, $UVLO = V_{EE}$, $T_A = -40^\circ C$ to $+85^\circ C$, unless otherwise noted. Typical values are at $T_A = +25^\circ C$. All voltages are referenced to V_{EE} , unless otherwise noted.) (Note 1)

PARAMETER	SYMBOL	CONDITIONS	MIN	TYP	MAX	UNITS	
UVLO Input Ground Sense Threshold (Note 8)	$V_{TH,G,UVLO}$		50		440	mV	
UVLO Input Ground Sense Glitch Rejection		$UVLO = V_{EE}$		7		μs	
Power Turn-Off Voltage, Undervoltage Lockout Deglitch Time (Note 9)	t_{OFF_DLY}	V_{IN} , V_{UVLO} falling	0.32			ms	
Isolation Switch N-Channel MOSFET On-Resistance	R_{ON}	Output current = 300mA, $V_{GATE} = 6V$, measured between OUT and V_{EE}	$T_A = +25^\circ C$ (Note 10)		0.6	1.1	Ω
			$T_A = +85^\circ C$		0.8	1.5	
Isolation Switch N-Channel MOSFET Off-Threshold Voltage	V_{GSTH}	OUT = GND, $V_{GATE} = V_{EE}$, output current < $1\mu A$	0.5			V	
GATE Pulldown Switch Resistance	R_G	Power-off mode, $V_{IN} = 12V$, $UVLO = V_{EE}$ for MAX5940B		38	80	Ω	
GATE Charging Current	I_G	$V_{GATE} = 2V$	5	10	15	μA	
GATE High Voltage	V_{GATE}	$I_{GATE} = 1\mu A$	5.59	5.76	5.93	V	
$PGOOD$, \overline{PGOOD} Assertion V_{OUT} Threshold	V_{OUTEN}	$V_{OUT} - V_{EE}$, $ V_{OUT} - V_{EE} $ decreasing, $V_{GATE} = 5.75V$	1.16	1.23	1.31	V	
		Hysteresis		70		mV	
$PGOOD$, \overline{PGOOD} Assertion V_{GATE} Threshold	V_{GSEN}	$(GATE - V_{EE})$ increasing, OUT = V_{EE}	4.62	4.76	4.91	V	
		Hysteresis		80		mV	
$PGOOD$, \overline{PGOOD} Output Low Voltage (Note 11)	$V_{OLDCCDC}$	$I_{SINK} = 2mA$; for $PGOOD$, OUT $\leq (GND - 5V)$			0.4	V	
$PGOOD$ Leakage Current (Note 11)		GATE = high, $GND - V_{OUT} = 67V$			1	μA	
\overline{PGOOD} Leakage Current (Note 11)		GATE = V_{EE} , $\overline{PGOOD} - V_{EE} = 67V$			1	μA	

Note 1: All min/max limits are production tested at $+85^\circ C$. Limits at $+25^\circ C$ and $-40^\circ C$ are guaranteed by design.

Note 2: The input offset current is illustrated in Figure 1.

Note 3: Effective differential input resistance is defined as the differential resistance between GND and V_{EE} without any external resistance. See Figure 1.

Note 4: Classification current is turned off whenever the IC is in power mode.

Note 5: See Table 2 in the *PD Classification Mode* section. R_{DISC} and R_{CL} must be $\pm 1\%$, 100ppm or better. I_{CLASS} includes the IC bias current and the current drawn by R_{DISC} .

Note 6: See the *Thermal Dissipation* section for details.

Note 7: When UVLO is connected to the midpoint of an external resistor-divider with a series resistance of $25.5k\Omega$ ($\pm 1\%$), the turn-on threshold set-point for the power mode is defined by the external resistor-divider. Make sure the voltage on the UVLO pin does not exceed its maximum rating of 8V when V_{IN} is at the maximum voltage (MAX5940B only).

Note 8: When the UVLO input voltage is below $V_{TH,G,UVLO}$, the MAX5940B sets the UVLO threshold internally.

Note 9: An input voltage or V_{UVLO} glitch below their respective thresholds shorter than or equal to t_{OFF_DLY} does not cause the MAX5940A/MAX5940B/MAX5940C/MAX5940D to exit power-on mode (as long as the input voltage remains above an operable voltage level of 12V).

Note 10: Guaranteed by design.

Note 11: $PGOOD$ references to OUT while \overline{PGOOD} references to V_{EE} .

IEEE 802.3af PD Interface Controller For Power-Over-Ethernet

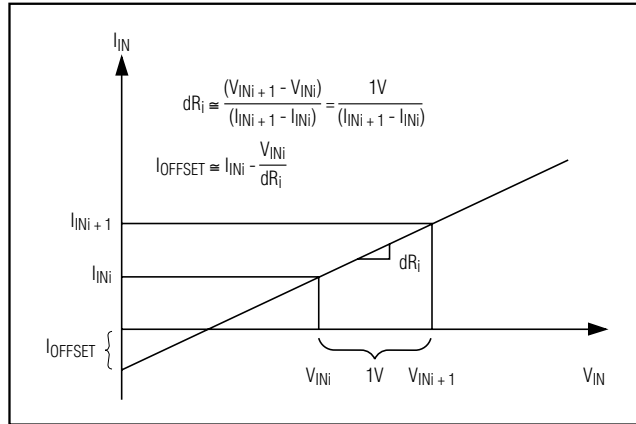
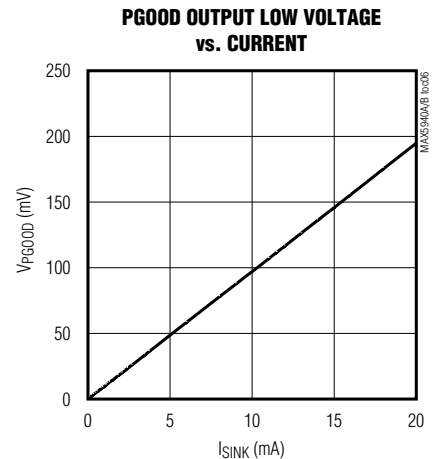
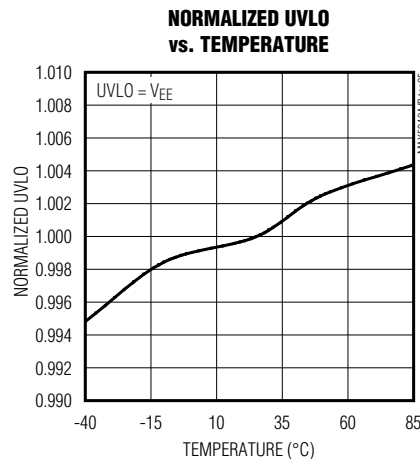
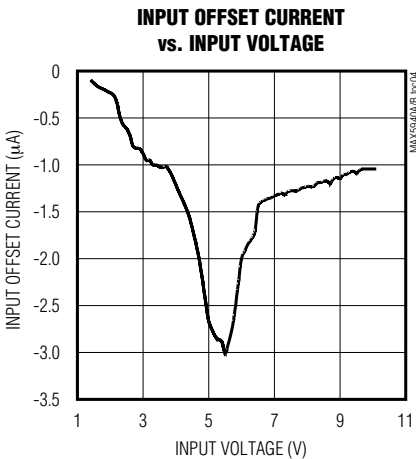
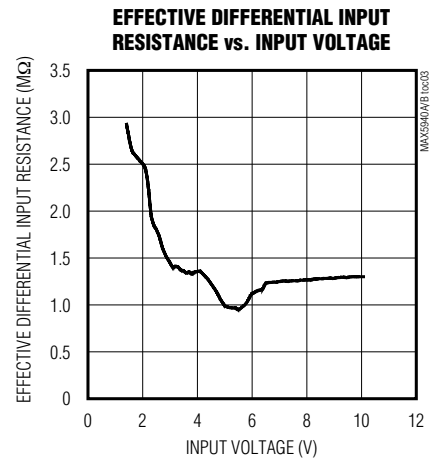
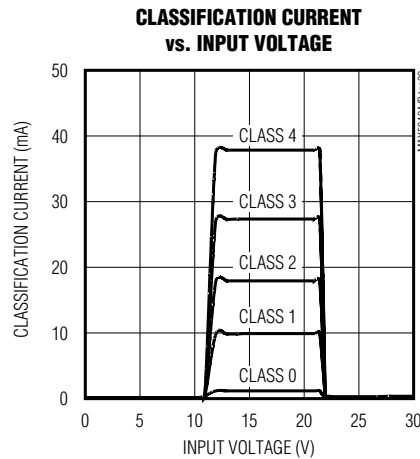
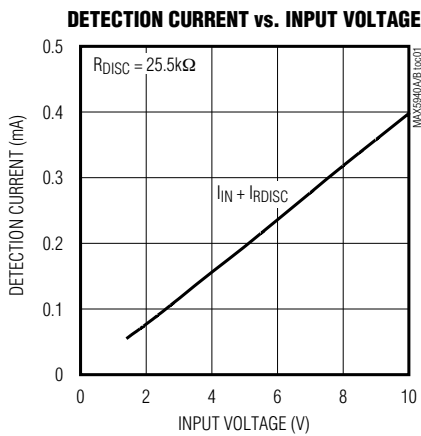

Figure 1. Effective Differential Input Resistance/Offset Current

Typical Operating Characteristics

($V_{IN} = (GND - V_{EE}) = 48V$, $GATE = \overline{PGOOD} = PGOOD = OUT = OPEN$, $UVLO = V_{EE}$ (MAX5940B), $T_A = -40^{\circ}C$ to $+85^{\circ}C$. Typical values are at $T_A = +25^{\circ}C$. All voltages are referenced to V_{EE} , unless otherwise noted.)



IEEE 802.3af PD Interface Controller For Power-Over-Ethernet

Typical Operating Characteristics (continued)

($V_{IN} = (GND - V_{EE}) = 48V$, $GATE = \overline{PGOOD} = PGOOD = OUT = OPEN$, $UVLO = V_{EE}$ (MAX5940B), $T_A = -40^{\circ}C$ to $+85^{\circ}C$. Typical values are at $T_A = +25^{\circ}C$. All voltages are referenced to V_{EE} , unless otherwise noted.)

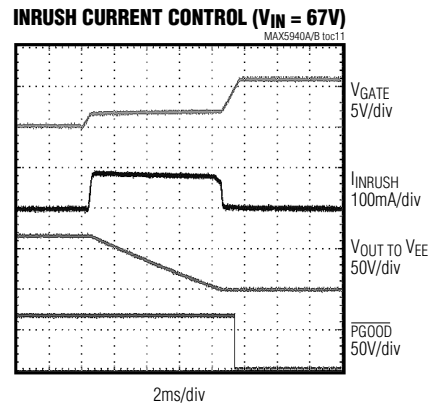
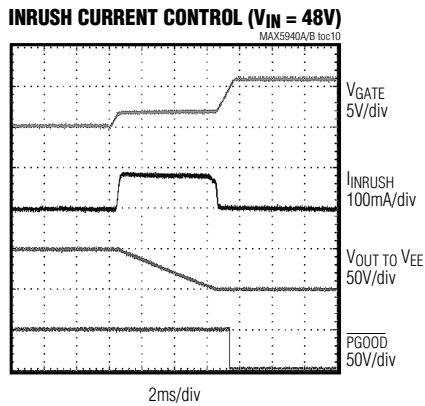
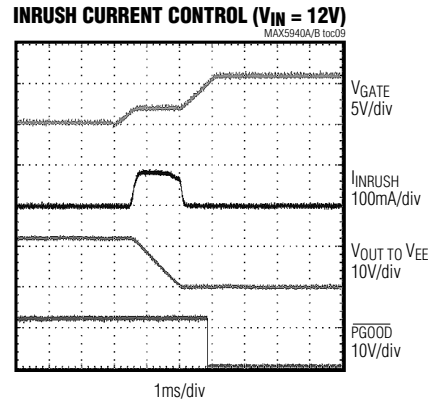
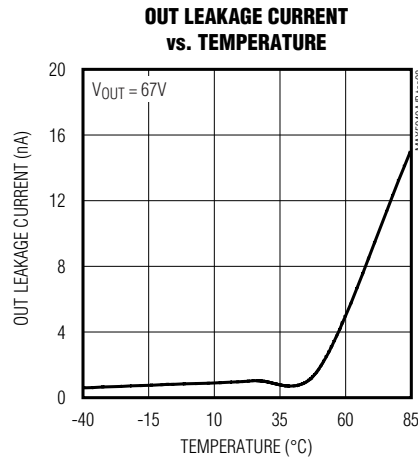
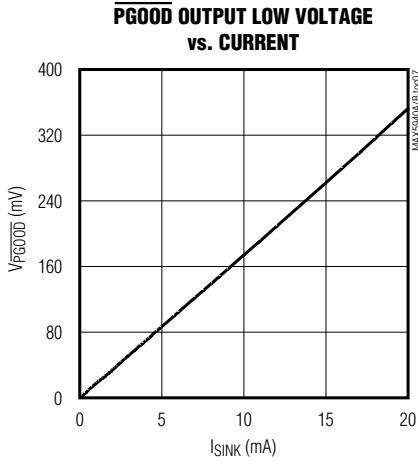

MAX5940A/MAX5940B/MAX5940C/MAX5940D

IEEE 802.3af PD Interface Controller For Power-Over-Ethernet

Pin Description

PIN		NAME	FUNCTION
MAX5940A/ MAX5940C	MAX5940B/ MAX5940D		
1, 7	—	N.C.	No Connection. Not internally connected.
—	1	UVLO	Undervoltage Lockout Programming Input for Power Mode. When UVLO is above its threshold, the device enters power mode. Connect UVLO to V_{EE} to use the default undervoltage lockout threshold. Connect UVLO to an external resistor-divider to define a threshold externally. The series resistance value of the external resistors must add to 25.5k Ω ($\pm 1\%$) and replaces the detection resistor. To keep the device in undervoltage lockout, pull UVLO to between $V_{TH,G,UVLO}$ and $V_{REF,UVLO}$.
2	2	RCLASS	Classification Setting. Add a resistor from RCLASS to V_{EE} to set a PD class (see Tables 1 and 2).
3	3	GATE	Gate of Internal N-Channel Power MOSFET. GATE sources 10 μ A when the device enters power mode. Connect an external 100V ceramic capacitor (C_{GATE}) from GATE to OUT to program the inrush current. Pull GATE to V_{EE} to turn off the internal MOSFET. The detection and classification functions operate normally when GATE is pulled to V_{EE} .
4	4	V_{EE}	Negative Input Power. Source of the integrated isolation N-channel power MOSFET. Connect V_{EE} to -48V.
5	5	OUT	Output Voltage. Drain of the integrated isolation N-channel power MOSFET.
6	6	PGOOD	Power-Good Indicator Output, Active-High, Open-Drain. PGOOD is referenced to OUT. PGOOD goes high impedance when V_{OUT} is within 1.2V of V_{EE} and when GATE is 5V above V_{EE} . Otherwise, PGOOD is pulled to OUT (given that V_{OUT} is at least 5V below GND). Connect PGOOD to the ON pin of a downstream DC-DC converter.
—	7	$\overline{\text{PGOOD}}$	Power-Good Indicator Output, Active-Low, Open-Drain. $\overline{\text{PGOOD}}$ is referenced to V_{EE} . $\overline{\text{PGOOD}}$ is pulled to V_{EE} when V_{OUT} is within 1.2V of V_{EE} and when GATE is 5V above V_{EE} . Otherwise, $\overline{\text{PGOOD}}$ goes high impedance. Connect $\overline{\text{PGOOD}}$ to the $\overline{\text{ON}}$ pin of a downstream DC-DC converter.
8	8	GND	Ground. GND is the positive input terminal.

Detailed Description

Operating Modes

The PD front-end section of the MAX5940_ operates in 3 different modes, PD detection signature, PD classification, and PD power, depending on its input voltage ($V_{IN} = GND - V_{EE}$). All voltage thresholds are designed to operate with or without the optional diode bridge while still complying with the IEEE 802.3af standard (see Figure 4).

Detection Mode ($1.4V \leq V_{IN} \leq 10.1V$)

In detection mode, the power source equipment (PSE) applies two voltages on V_{IN} in the range of 1.4V to 10.1V

(1V step minimum), and then records the current measurements at the two points. The PSE then computes $\Delta V/\Delta I$ to ensure the presence of the 25.5k Ω signature resistor. In this mode, most of the MAX5940_ internal circuitry is off and the offset current is less than 10 μ A.

If the voltage applied to the PD is reversed, install protection diodes on the input terminal to prevent internal damage to the MAX5940_ (see the *Typical Application Circuits*). Since the PSE uses a slope technique ($\Delta V/\Delta I$) to calculate the signature resistance, the DC offset due to the protection diodes is subtracted and does not affect the detection process.

IEEE 802.3af PD Interface Controller For Power-Over-Ethernet

MAX5940A/MAX5940B/MAX5940C/MAX5940D

Table 1. PD Power Classification/R_{CL} Selection

CLASS	USAGE	R _{CL} (Ω)	MAXIMUM POWER USED BY PD (W)
0	Default	10k	0.44 to 12.95
1	Optional	732	0.44 to 3.84
2	Optional	392	3.84 to 6.49
3	Optional	255	6.49 to 12.95
4	Not Allowed	178	Reserved*

*Class 4 reserved for future use.

Table 2. Setting Classification Current

CLASS	R _{CL} (Ω)	V _{IN} * (V)	CLASS CURRENT SEEN AT V _{IN} (mA)		IEEE 802.3af PD CLASSIFICATION CURRENT SPECIFICATION (mA)	
			MIN	MAX	MIN	MAX
0	10k	12.6 to 20	0	2	0	4
1	732	12.6 to 20	9.17	11.83	9	12
2	392	12.6 to 20	17.29	19.71	17	20
3	255	12.6 to 20	26.45	29.55	26	30
4	178	12.6 to 20	36.6	41.4	36	44

*V_{IN} is measured across the MAX5940 input pins, which does not include the diode bridge voltage drop.

Classification Mode (12.6V ≤ V_{IN} ≤ 20V)

In the classification mode, the PSE classifies the PD based on the power consumption required by the PD. This allows the PSE to efficiently manage power distribution. The IEEE 802.3af standard defines five different classes as shown in Table 1. An external resistor (R_{CL}) connected from RCLASS to V_{EE} sets the classification current.

The PSE determines the class of a PD by applying a voltage at the PD input and measures the current sourced out of the PSE. When the PSE applies a voltage between 12.6V and 20V, the MAX5940_ exhibit a current characteristic with values indicated in Table 2. The PSE uses the classification current information to classify the power requirement of the PD. The classification current includes the current drawn by the 25.5kΩ detection signature resistor and the supply current of the MAX5940_ so the total current drawn by the PD is within the IEEE 802.3af standard figures. The classification current is turned off whenever the device is in power mode.

Power Mode

During power mode, when V_{IN} rises above the under-voltage lockout threshold (V_{UVLO,ON}), the MAX5940_ gradually turn on the internal N-channel MOSFET Q1

(see Figure 2). The MAX5940_ charge the gate of Q1 with a constant current source (10μA, typ). The drain-to-gate capacitance of Q1 limits the voltage rise rate at the drain of the MOSFET, thereby limiting the inrush current. To reduce the inrush current, add external drain-to-gate capacitance (see the *Inrush Current Limit* section). When the drain of Q1 is within 1.2V of its source voltage and its gate-to-source voltage is above 5V, the MAX5940_ asserts the PGOOD/PGOOD outputs. The MAX5940_ have a wide UVLO hysteresis and turn-off deglitch time to compensate for the high impedance of the twisted-pair cable.

Undervoltage Lockout

The MAX5940_ operate up to a 67V supply voltage with a default UVLO turn-on (V_{UVLO,ON}) set at 35V (MAX5940A/MAX5940C) or 39V (MAX5940B/MAX5940D) and a UVLO turn-off (V_{UVLO,OFF}) set at 30V. The MAX5940B/MAX5940D have an adjustable UVLO threshold using a resistor-divider connected to UVLO (see Figure 3). When the input voltage is above the UVLO threshold, the IC is in power mode and the MOSFET is on. When the input voltage goes below the UVLO threshold for more than t_{OFF_DLY}, the MOSFET turns off.

IEEE 802.3af PD Interface Controller For Power-Over-Ethernet

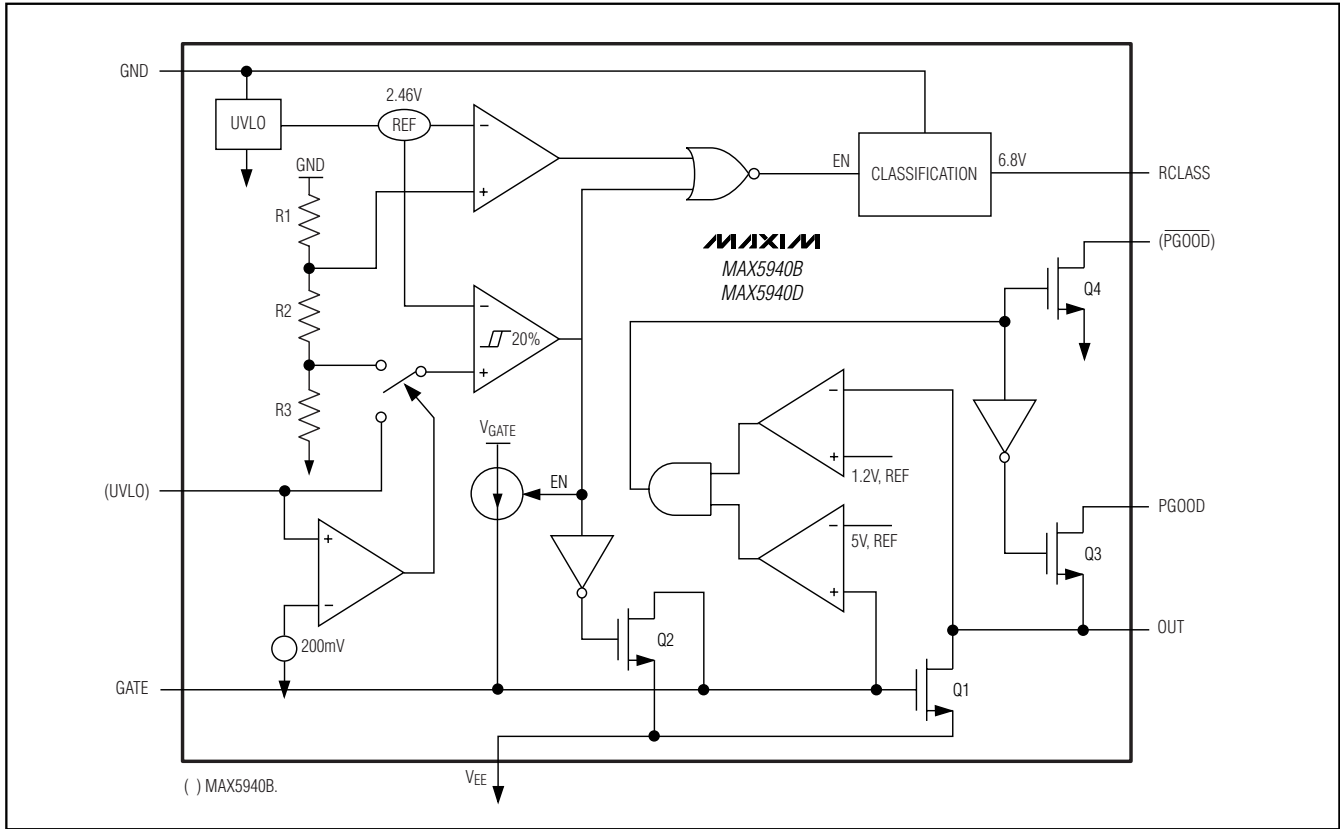

Figure 2. Block Diagram

To adjust the UVLO threshold (MAX5940B/MAX5940D only), connect an external resistor-divider from GND to UVLO and from UVLO to VEE. Use the following equations to calculate R1 and R2 for a desired UVLO threshold:

$$R2 = 25.5k\Omega \times \frac{V_{REF,UVLO}}{V_{IN,EX}}$$

$$R1 = 25.5k\Omega - R2$$

where $V_{IN,EX}$ is the desired UVLO threshold. Since the resistor-divider replaces the 25.5kΩ PD detection resistor, ensure that the sum of R1 and R2 equals 25.5kΩ ±1%. When using the external resistor-divider, the MAX5940B/MAX5940D has an external reference voltage hysteresis of 20% (typ). When UVLO is programmed externally, the turn-off threshold is 80% (typ) of the new UVLO threshold.

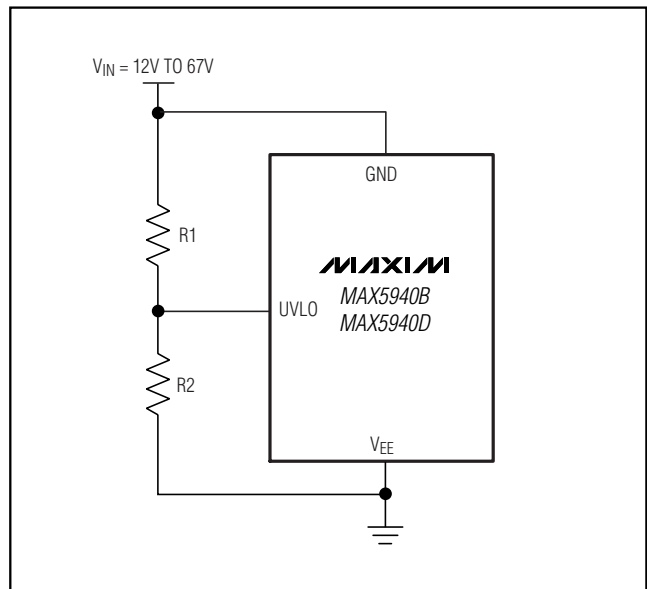

Figure 3. Setting Undervoltage Lockout with an External Resistor-Divider

IEEE 802.3af PD Interface Controller For Power-Over-Ethernet

Inrush Current Limit

The MAX5940_ charge the gate of the internal MOSFET with a constant current source (10μA, typ). The drain-to-gate capacitance of the MOSFET limits the voltage rise rate at the drain, thereby limiting the inrush current. Add an external capacitor from GATE to OUT to further reduce the inrush current. Use the following equation to calculate the inrush current:

$$I_{\text{INRUSH}} = I_G \times \frac{C_{\text{OUT}}}{C_{\text{GATE}}}$$

PGOOD/PGOOD Outputs

(MAX5940A/MAX5940C only)

PGOOD is an open-drain, active-high logic output. PGOOD goes high impedance when V_{OUT} is within 1.2V of V_{EE} and when GATE is 5V above V_{EE}. Otherwise, PGOOD is pulled to V_{OUT} (given that V_{OUT} is at least 5V below GND). Connect PGOOD to the ON pin of a downstream DC-DC converter. Connect a 100kΩ pullup resistor from PGOOD to GND if needed.

(MAX5940B/MAX5940D only)

PGOOD is an open-drain, active-low logic output. PGOOD is pulled to V_{EE} when V_{OUT} is within 1.2V of V_{EE} and when GATE is 5V above V_{EE}. Otherwise, PGOOD goes high impedance. Connect PGOOD to the ON pin of a downstream DC-DC converter. Connect a 100kΩ pullup resistor from PGOOD to GND if needed.

Thermal Dissipation

During classification mode, if the PSE applies the maximum DC voltage, the maximum voltage drop from GND to V_{RCLASS} will be 13V. If the maximum classification current of 42mA flows through the MAX5940_, then the maximum DC power dissipation will be 546mW, which is slightly higher than the maximum DC power dissipation of the IC at maximum operating temperature. However, according to the IEEE 802.3af standard, the duration of the classification mode is limited to 75ms (max). The MAX5940_ handle the maximum classification power dissipation for the maximum duration time without sustaining any internal damage. If the PSE violates the IEEE 802.3af standard by exceeding the 75ms maximum classification duration, it may cause internal damage to the IC.

MAX5940A/MAX5940B/MAX5940C/MAX5940D

IEEE 802.3af PD Interface Controller For Power-Over-Ethernet

Typical Application Circuits

Application Circuit 1

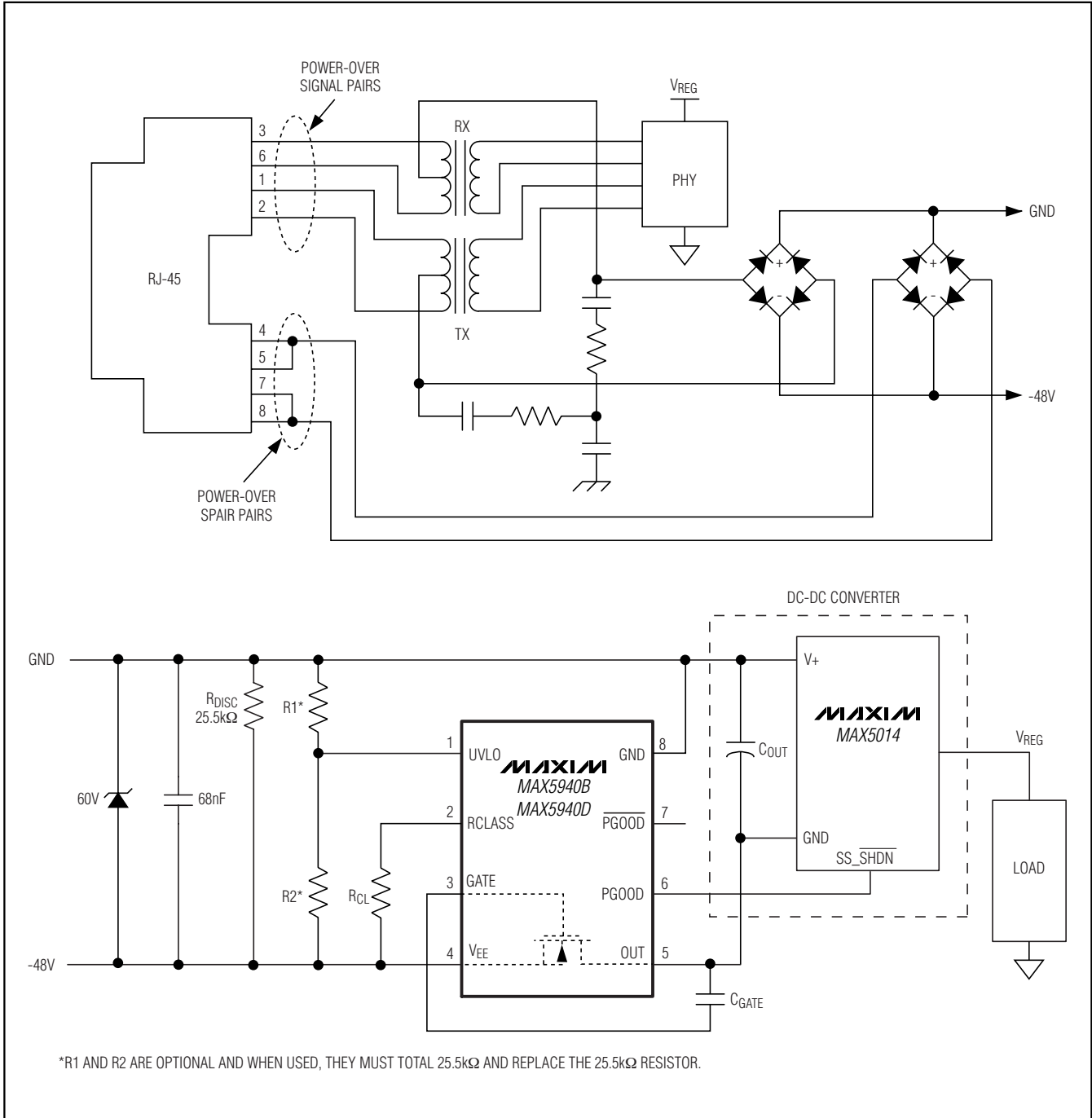

Figure 4. PD with Power-Over-Ethernet (Power is Provided by Either the Signal Pairs or the Spare Pairs)

IEEE 802.3af PD Interface Controller For Power-Over-Ethernet

Typical Application Circuits (continued)

Application Circuit 2

Diode D1 prevents the power-over-ethernet to back drive the wall adapter. Whenever the wall adapter power is greater than ($V_{D3} +$ approximately 2V), the

GATE is pulled low to pinch off the power-over-ethernet. The wall adapter power pollutes the discovery signature, preventing PSE from detecting this PD.

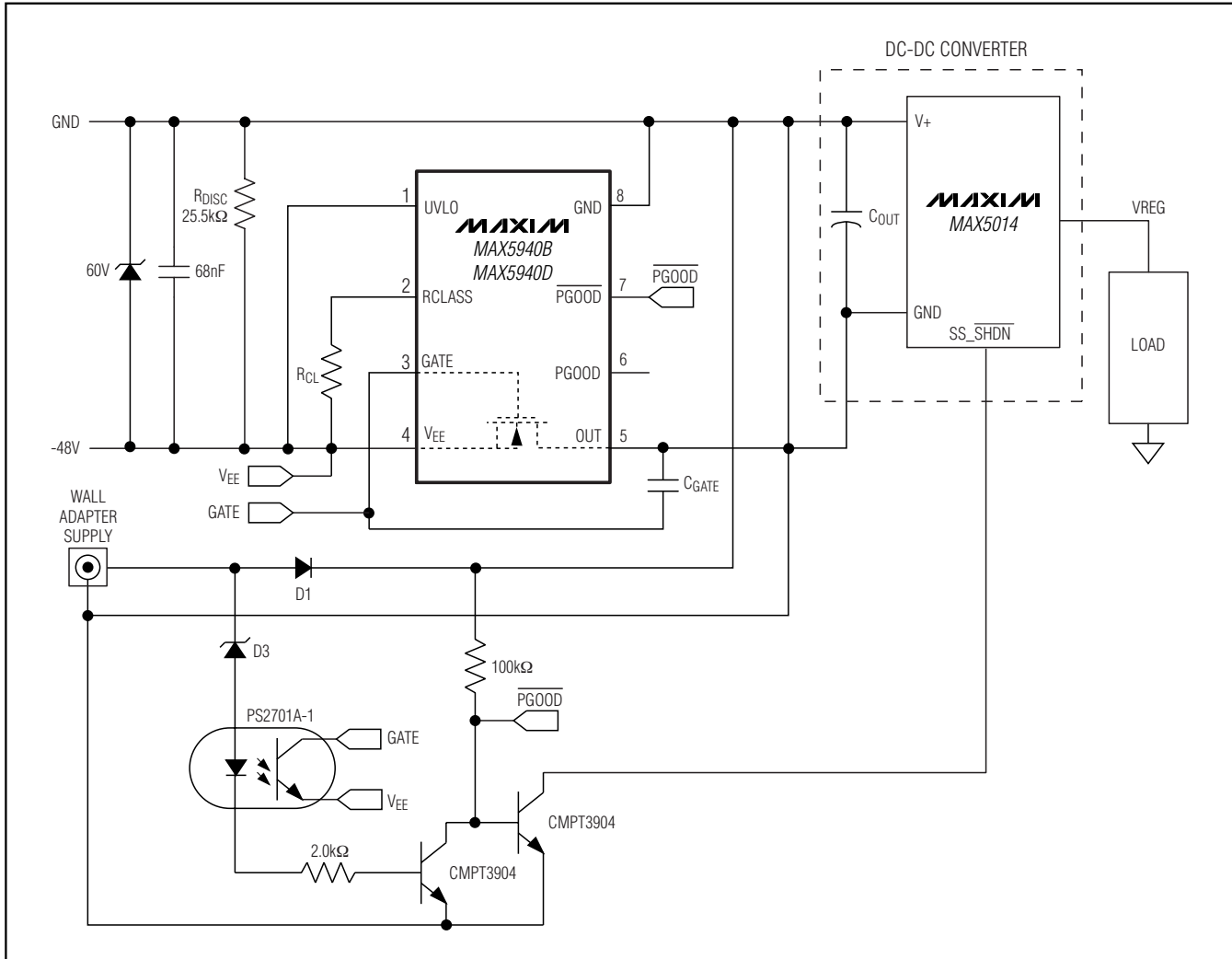

Figure 5. Adding Wall Adapter Input Supply (Wall Adapter Supply Takes Precedence Over Power-Over-Ethernet)

MAX5940A/MAX5940B/MAX5940C/MAX5940D

IEEE 802.3af PD Interface Controller For Power-Over-Ethernet

Typical Application Circuits (continued)

Application Circuit 3

D2 prevents the wall adapter power from polluting the discovery and classification signatures. The optional

R4 provides the 10mA minimum power maintenance signature to keep the power-over-ethernet from disconnecting.

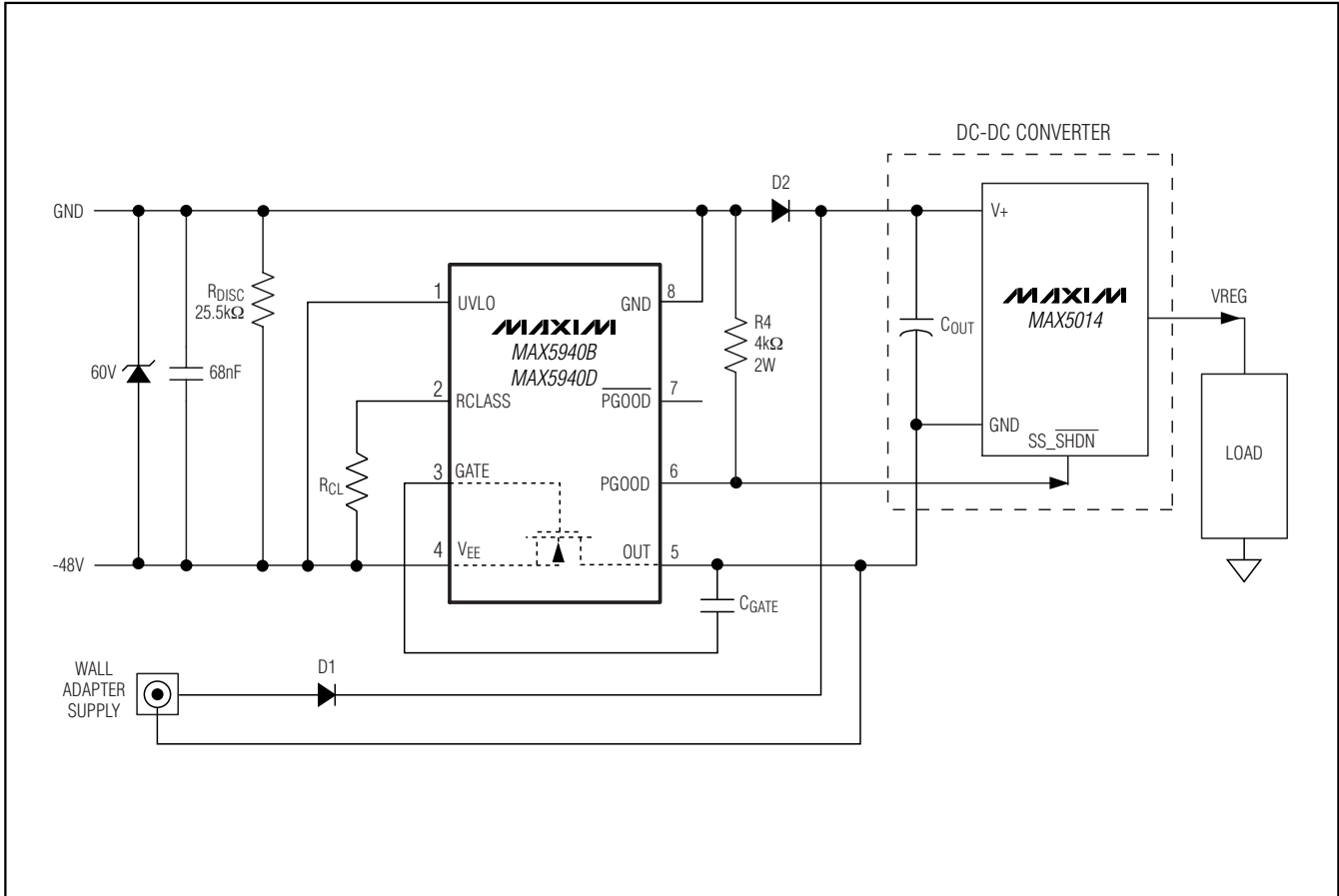

Figure 6. Adding Wall Adapter Input Supply (Wall Adapter Supply And Power-Over-Ethernet Co-Exist, the One with Higher Voltage Provides Power To The Load)

IEEE 802.3af PD Interface Controller For Power-Over-Ethernet

Typical Application Circuits (continued)

Application Circuit 4

If the wall adapter supply comes up first, it provides power to the load and pollute the discovery and classi-

fication signatures. If the power-over-ethernet comes up first, it powers the load until taken over by a wall adapter with higher output voltage.

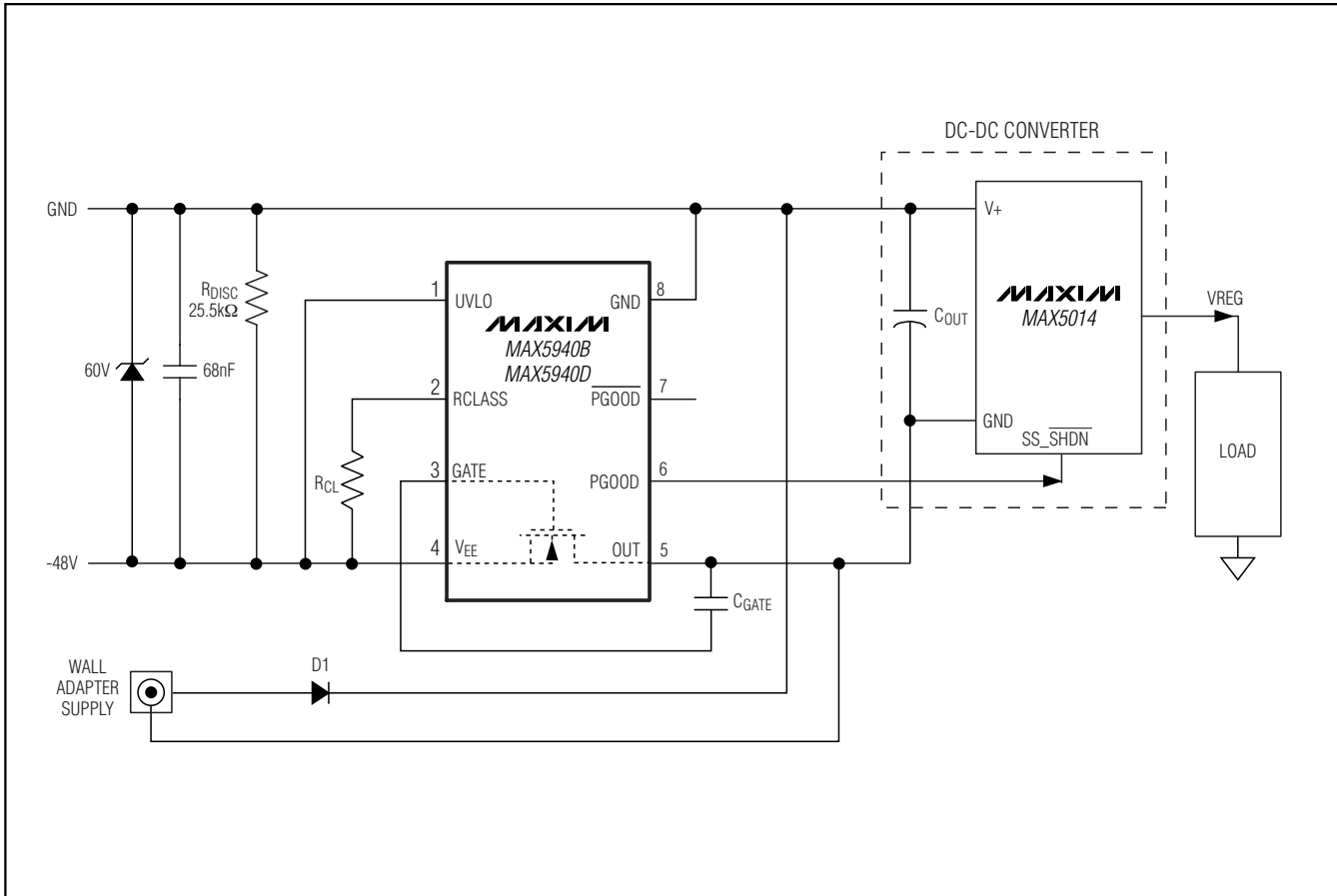
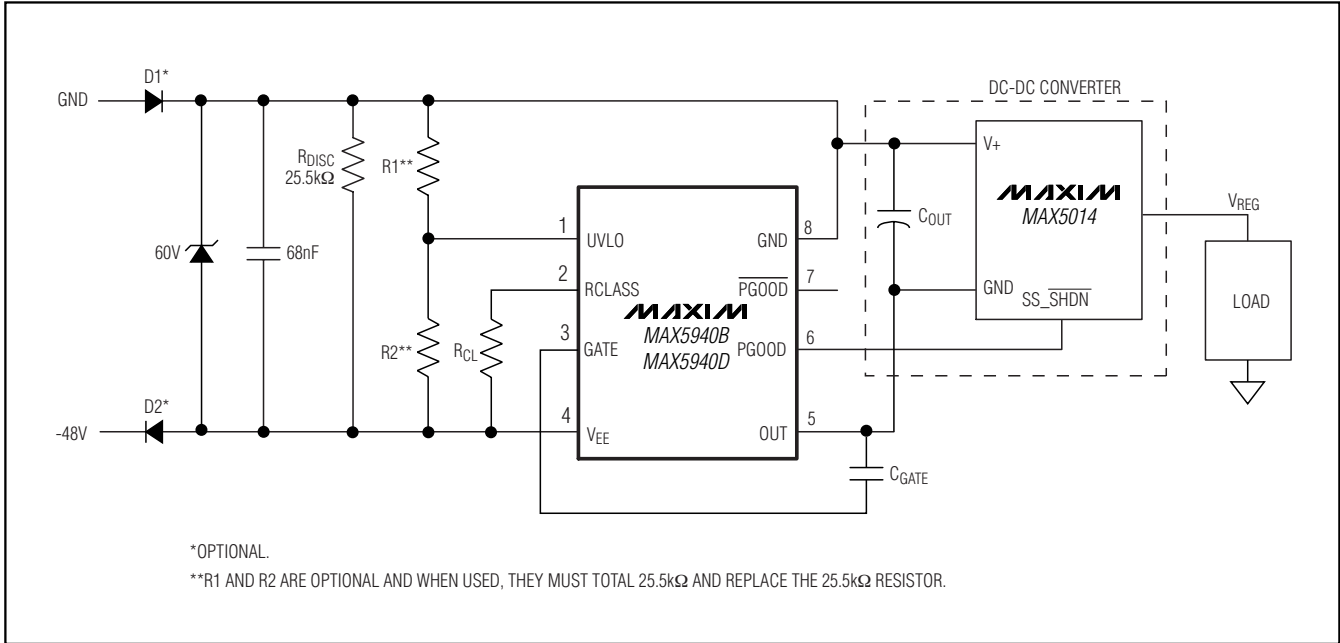

Figure 7. Adding Wall Adapter Input Supply (the One with Higher Voltage Provides Power to the Load)

MAX5940A/MAX5940B/MAX5940C/MAX5940D

IEEE 802.3af PD Interface Controller For Power-Over-Ethernet

Typical Operating Circuits (continued)



Pin Configurations

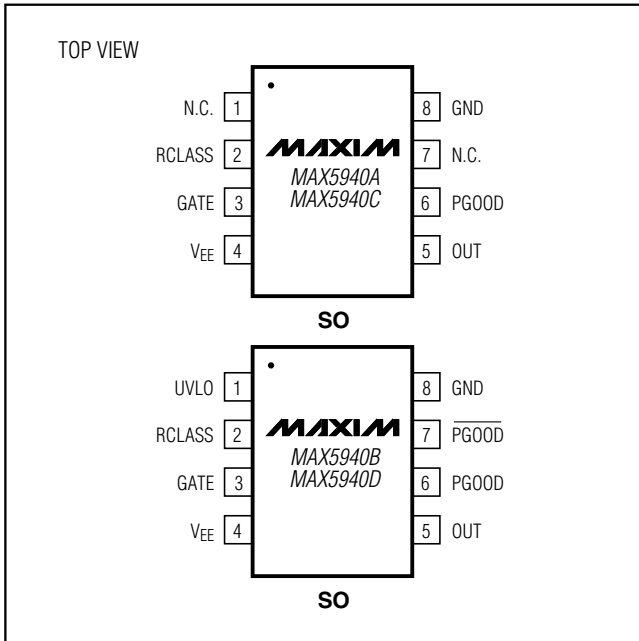

Chip Information

TRANSISTOR COUNT: 3,643
PROCESS: BiCMOS

IEEE 802.3af PD Interface Controller For Power-Over-Ethernet

Package Information

(The package drawing(s) in this data sheet may not reflect the most current specifications. For the latest package outline information, go to www.maxim-ic.com/packages.)

MAX5940A/MAX5940B/MAX5940C/MAX5940D

SOICN .EPS

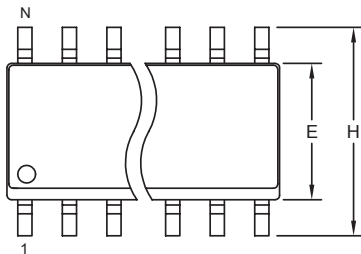

TOP VIEW

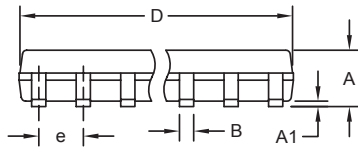

FRONT VIEW

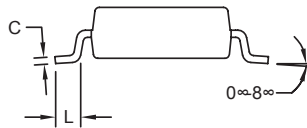

SIDE VIEW

DIM	INCHES		MILLIMETERS	
	MIN	MAX	MIN	MAX
A	0.053	0.069	1.35	1.75
A1	0.004	0.010	0.10	0.25
B	0.014	0.019	0.35	0.49
C	0.007	0.010	0.19	0.25
e	0.050 BSC		1.27 BSC	
E	0.150	0.157	3.80	4.00
H	0.228	0.244	5.80	6.20
L	0.016	0.050	0.40	1.27

VARIATIONS:

DIM	INCHES		MILLIMETERS		N	MS012
	MIN	MAX	MIN	MAX		
D	0.189	0.197	4.80	5.00	8	AA
D	0.337	0.344	8.55	8.75	14	AB
D	0.386	0.394	9.80	10.00	16	AC

NOTES:

1. D&E DO NOT INCLUDE MOLD FLASH.
2. MOLD FLASH OR PROTRUSIONS NOT TO EXCEED 0.15mm (.006").
3. LEADS TO BE COPLANAR WITHIN 0.10mm (.004").
4. CONTROLLING DIMENSION: MILLIMETERS.
5. MEETS JEDEC MS012.
6. N = NUMBER OF PINS.

<small>PROPRIETARY INFORMATION</small>	
<small>TITLE:</small> PACKAGE OUTLINE, .150" SOIC	
<small>APPROVAL</small>	<small>DOCUMENT CONTROL NO.</small> 21-0041
<small>REV.</small> B	<small>1/1</small>

Maxim cannot assume responsibility for use of any circuitry other than circuitry entirely embodied in a Maxim product. No circuit patent licenses are implied. Maxim reserves the right to change the circuitry and specifications without notice at any time.

Maxim Integrated Products, 120 San Gabriel Drive, Sunnyvale, CA 94086 408-737-7600 _____ 15